



Inverts loads for pallet or slipsheet transfer.

Inverts loads for pallet or slipsheet transfer and allows driver to recover product from bottom of stack.

APPLICATIONS

Designed to provide a reliable, economical and efficient means of inverting loads. Allows transfer of product to pallet or slipsheet, freezer spacer removal, damaged pallet exchange or damaged carton replacement. Also provides system for damaged product recovery from bottom of stack.

FEATURES

- Proven Cascade rotator with stops
- Self-contained power pack
- Adjustable relief valve
- Fork pockets for easy relocation
- Swing arm control

OPTIONS

- Load pusher
- Drum mixing arms
- Stainless steel paint for food processing applications
- Conveyor bed
- Pallet retention
- Take-it-or-leave-it application
- Variable platform sizes
- Variable opening ranges
- Floor-level loading
- 360° rotation

MODELS

- 220V
- 440V
- 550V triple phase



STATIONARY LOAD INVERTER

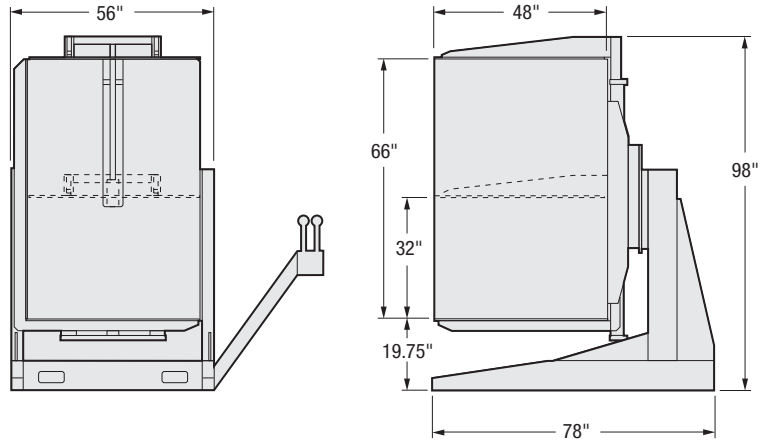

Economical & Efficient

- Pallet transfer
- Transfer to slipsheets
- Freezer spacer removal
- Damaged pallet exchange
- Damaged carton replacement

Capacity @ Load Center	Opening Range	Catalog Order No.	Platform Size (W x L)	Fixed Stabilizer (L x H)	Rotation	Weight	'Footprint' (WxL)
lbs. @ inches (kg @ mm)						lbs. (kg)	
4,000 @ 24" (1,800 @ 610)	32"-66"	40C-SLI-A100	48" x 48"	48" x 66"	180°	4,600 (2,090)	56" x 78"

► Stationary Load Inverters are built to order. When ordering please specify:

- "Transfer To" and "Transfer From," pallet size, material and construction
- Material to be handled and how to be packaged
- Load weight and size (H x W x L)
- Voltage and phase requirement

HOW IT WORKS:

- ① The unit load is placed into the Stationary Load Inverter with a second pallet on top.
- ② The product is clamped at the required pressure by the top clamp arm.
- ③ Stationary Load Inverter is rotated 180° and the load is transferred to what was the top pallet.
- ④ The clamp is released.

STANDARD CONTROL

- 2-Spool valve mounted on swing arm

CONTROL OPTIONS

- Computerized Control
- Radio Control
- 4-Button or 6-Button Pendant Control

SPECIFICATION OPTIONS

- Variable Platform Sizes
- Variable Opening Ranges
- Floor Level Loading
- 360° Rotation

POWER PACK SPECIFICATIONS

- Pump: 7.5 GPM
- Reservoir: 20 gallons
- Motor: 10 HP
- Adjustable relief valve
- In-line 10 micron filter

VOLTAGE

- 220V, 440V, 550V triple phase

