

MOBILE WEIGHING



Save time and money by weighing your product as you move it.



Plug and Weigh.

The next generation in mobile weighing.

iForks Pro are designed to save money by combining transport and weighing into one easy and efficient step. View and track the weight of individual loads or multiple loads using integrated Bluetooth® technology. Being wireless, the system can be installed onto any lift truck in a matter of minutes.

The applications are practically limitless, but most commonly used for incoming goods control, overload prevention, dosing, filling, waste management, order picking and inventory control.



A model for any application.

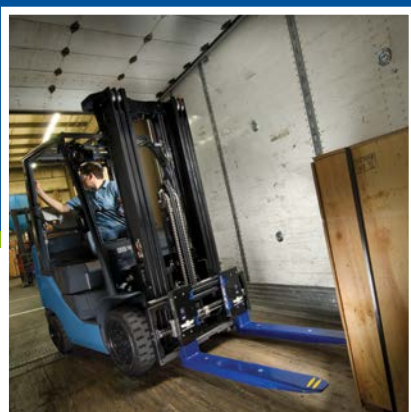

iForks Pro

Weigh and transport in one easy step. The completely wireless system installs in minutes for weighing on the go and can be used in combination with Fork Positioners.. Scale components are easily accessible and digitally calibrated.



Logistics iForks Pro

Featuring a thinner profile than standard iForks Pro, Logistics iForks Pro fit into the fork pockets of standard GMA pallets and other pallets that require a thinner fork.

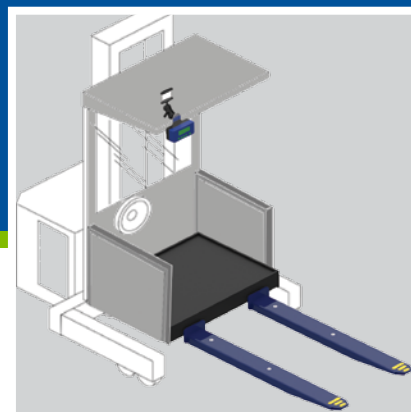

Order Picker iForks Pro

Custom designed to fit your specific Order Picker truck. Provides the ability to utilize all the features of our iForks Pro.



EFFICIENT

*Economically priced
with low installation costs.*

ROBUST

Each fork is equipped with its own battery module eliminating cable reels and power cords between the forks. The sealed rechargeable battery pack last over 1,000 charges.

ADVANCED

The Bluetooth® transmitters and calibration board are integrated into the forks to avoid risk of damage which means less downtime. Both forks communicated independently with the driver display.

SUPERIOR

Chisel tip forks with vibrant yellow inserts ensure that the driver can easily see the fork tips from above and below as they drive into the pallet.

Mobile Weighing Options and Accessories

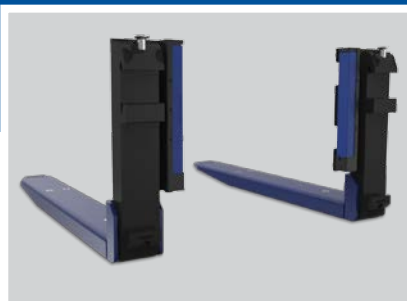

Rotator iFork

iForks Pro can be used on Rotators, making them ideal in applications such as mixing, dosing and waste management.

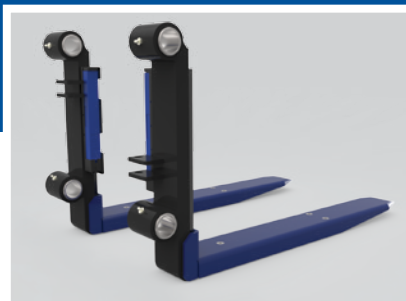

Shaft/Pin Type Fork

For use on trucks having a shaft or pin-type carriage enabling iForks Pro further versatility.



iForks Printers

Thermal Printers, Dot Matrix Printers or Barcode Printers are available for immediate output of load data.

Whatever the application. We can handle it.

Mobile weighing increases productivity and efficiency.



Checking Incoming Goods

Check incoming goods while they are being offloaded from the freight truck. If an incomplete delivery is identified, you can react on the spot to prevent stock differences and interrupted production processes.



Preventing Picking Errors

Weighing on order picking trucks helps prevent picking errors: if you know your article weight, you can check per order line, via the weight, whether the right amount of the right article has been picked. (Note: Piece counting feature is not legal for trade.)



Filling, Mixing and Dosing

Accurate filling of drums, containers and big bags means there is no unnecessary loss of material. By weighing the containers during transport on a forklift you achieve a higher efficiency and flexibility in your filling processes.



Preventing Overloads

Avoid the expenses and dangers of overloading freight trucks or warehouse racks. Mobile scales weigh every pallet as they are loaded to ensure the recommended weight is never exceeded.



Waste Control

Monitoring waste flows and knowing how much waste is produced at each spot in the production line, is the first step towards controlling and minimizing waste.



Shipping

Every company that ships goods needs to know the weight of these goods as accurately as possible. The sender is required by law to declare the correct weight on the shipping documents. Determining shipping weights is probably the most common use of a mobile scale.

Cascade Corporation • PO Box 20187 • Portland, OR 97294-0187 • USA • 800 CASCADE (227.2233) • Tel 503.669.6257 • Fax 800.693.3768 • Fax 503.669.6367
Cascade Canada Ltd. • 5570 Timberlea Blvd. • Mississauga, Ontario L4W 4M6 • Canada • 800.380.2272 • Tel 905.629.7777 • Fax 905.629.7785

cascade
corporation

www.cascorp.com